



Shenzhen Yunyue Intelligent Technology Co., Ltd.

Address: Building 9, 1901, Qianhai Kexing Science Park, Laodong Community, Xixiang Street, Bao'an District, Shenzhen, Guangdong, P.R.C.

Philips and the Philips Shield Emblem are registered trademarks of Koninklijke Philips N.V. and are used under license.

This product has been manufactured by and is sold under the responsibility of Shenzhen Yunyue Intelligent Technology Co., Ltd. and Shenzhen Yunyue Intelligent Technology Co., Ltd. is the warrantor of this product.

© 2024 Shenzhen Yunyue Intelligent Technology Co., Ltd. All rights reserved. Shenzhen Yunyue Intelligent Technology Co., Ltd. reserves the rights to change content and product specifications included in this user manual without prior notice at any time.

Version: 1.0

PHILIPS

1000 Series

Smart safe box

SBX102

User manual



To register your product as well as obtain support, please go to: www.philips.com/support

Product name	Philips smart safe box SBX102
Model	SBX102-2C0
Dimensions (HxWxD)	240x320x420 mm
Input voltage	4.5V~6 V
Operating temperature	-10°C ~+40°C
Operating humidity	30%RH~85%RH

Get to know your smart safe box	01
First use	03
Register fingerprint and PIN code	04
Delete fingerprint and PIN code	05
Placeholder password	06
Continuous retry failure lockout	07
Low battery alert	08
After-sales support	09
Warranty card	10

Please read this user manual carefully before using this product.

Thank you for purchasing Philips-branded products. For your safety, please read this user manual carefully before using the product. Any personal injury, property or other loss caused by not following the user manual or precautions, no liability will be assumed by Philips.

Kind reminder:

This user manual is used as a guide. The photos, pictures, or illustrations provided in the manual are for explanation purposes, which may differ from the specific product, please refer to the actual product. Due to product version upgrade or other needs, Yunyue may update this manual timely without prior notice. If you need the latest version of the manual, please download it from the Philips website (www.philips.com/sup-port). The copyright of any part from this manual, including text, pictures or illustrations, belongs to Yunyue. Without written permission, no corporation or individual may extract, copy, translate, or modify all or part of this manual in any way. Unless otherwise agreed, Yunyue does not make any expressions or implied representations and guarantees.

Get to know your smart safe box

1. Unlocking panel
2. Door
3. Cabinet
4. Battery compartment
5. Mechanical key
6. Emergency key hole
7. Upper drawer
8. Lower drawer
9. Setting

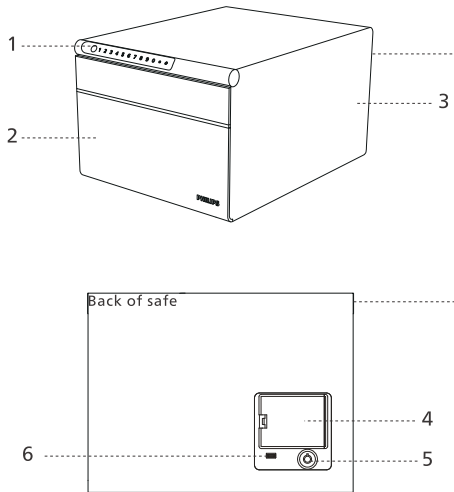

Figure 1

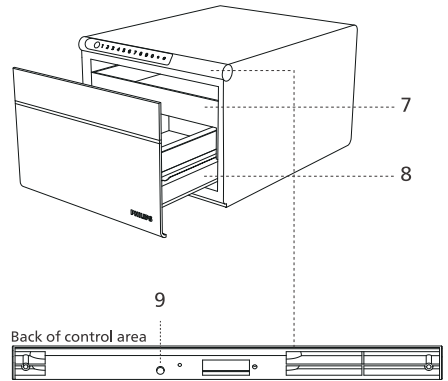

Figure 2

First use



Figure 3

1. Open the power box on the back of the safe and insert 4 AA batteries to power it on.
2. Enter any fingerprint or touch the numeric keypad to wake up the panel. Input the initial password "123456" and press the "#" key to confirm. The indicator light will turn green, the buzzer will beep once, and the door will automatically open, completing the initial setup.

Register fingerprint and PIN code

1. Open the safe, press the "Set" button briefly, or wake up the numeric keypad and press "*#", and the indicator light will turn pink, entering the key setting mode.
2. Verify the administrator key (input the initial password "123456" and press "#" to confirm). The indicator light will flash green. Enter a 4-6 digit password and press "#" to confirm. The green light will flash. Repeat the process once. If the buzzer sounds a long beep and the green light stays on, the password setup is successful. A flashing red light indicates a failure.
3. After the password is successfully set, you can proceed to configure fingerprints. While the green light is flashing, press your finger at different angles 5 times (each press will make a short "beep" sound). If the buzzer sounds a long beep and the green light stays on, the fingerprint setup is successful. A flashing red light indicates a failure.

⚠ Attention:

1. The admin fingerprint and PIN code are the first three fingerprints/PIN codes registered.
2. After setting the fingerprint and PIN code, verify once before closing the drawer to ensure its effectiveness. The system automatically exits after 8 seconds of no operation during fingerprint and PIN code setup.
3. After the current credential is successfully set (a long beep from the buzzer), a "beep-beep" sound indicates that you can proceed to set the next key.
4. The fingerprint capacity is 120, and the PIN code capacity is 100.

Delete fingerprint and PIN code

In the door-open state, press and hold the "Set" button for 10 seconds. The buzzer will emit two short "beep-beep" sounds. Release the button, and the green light will stay on while the buzzer sounds a long beep. This will clear all keys and reset the system to its initial mode.

Placeholder password

This safe supports placeholder password function, allowing you to random the correct password within a series of input digits and press "#" to confirm to open the safe. For example, if the recorded password is "123123," entering "94628812312355778" and pressing "#" will also unlock the door.

 Attention: Up to 20 valid digits can be entered.

Continuous retry failure lockout

If 5 consecutive fingerprint entries or 3 consecutive password entries are incorrect, the system will trigger an error alert. The indicator light will remain on for 8 seconds, and the system will lock for 60 seconds.

⚠ Attention: During the lockout period caused by consecutive incorrect entries, no operations can be performed on the safe. After a power cycle or waiting 60 seconds, the system will return to normal.

Low battery alert

When the system detects that the power supply is below 4.8V, it will activate a low voltage warning. The indicator light will flash red during use, signaling that you should replace the batteries promptly.

⚠ Attention:

1. Replace the batteries as soon as the low voltage warning appears; otherwise, insufficient voltage may affect normal operation.
2. If batteries are not replaced in time, you can use the mechanical key or connect an external power source via the Type-C port for emergency power to open the safe.

After-sales support

If you encounter any problems when using the product, please contact local authorized distributors.

Warranty card

Product model		Product serial number		
Invoice No.		Seller		
Address of seller				
Date of sales		User name		
Contact of user		Address of user		
Failure description				
Maintenance records	Date	Issue	Maintenance staff	User signature

